

Ball Valve

BP

2-PC Stainless Steel Ball Valve
Full Port, Flange Ends, 1000WOG, PN10-40 (ISO-Direct Mounting Pad)

FEATURES:

- Blow-out Proof Stem
- Anti-Static Device for Ball-Stem-Body
- Pressure Balance Hole in Ball Slot
- 2 Belleville Washer to Self-adjust Packing
- ISO 5211 Direct Mounting Pad for Easy Automation
- Locking Device Spring Handle, **New Design**

STANDARD:

- Design: EN 12516-1
- Wall Thickness: ASME B16.34, EN 12516-3
- Flange Ends: DIN 2501 PN10-PN40
- **Fire Safe** Design Acc: API 607
- Flange End: ASME B16.5 CLASS 150/300
DIN 2653 PN10-PN40
JIS B2238 10K/20K
- Inspection & Testing: API 598, EN 12266

NO	PARTS NAME	MATERIAL	
1	Body	CF8M	CF8 WCB
2	Nut	SS304	SS301
3	Cap	CF8M	CF8 WCB
4	Cap Gasket	PTFE	VITON
5	Ball Seat	PTFE	R-PTFE
6	Ball	CF8M	CF8
7	Stem Packing	PTFE	R-PTFE
8	Bushing	50%SS+50%PTFE/SS304	
9	Packing Gland	SS304	
10	Belleville Washer	SS301	
11	Stop Nut	SS304	
12	Stop-Lock Cap	SS301	
13	Washer	SS301	
14	Position Handle	SS301	
15	Stem Nut	SS301	
16	Plastic Pin	Plastic	
17	Locking Device	SS301	
18	Handle Cover	Plastic	
19	Stem	SS316	SS304
20	O-Ring	FKM(VITON)	
21	Thrust Washer	PTFE	
22	Anti-Static Device	SS301	
23	Stop Bolt	SS301	
24	Bolt	SS301	

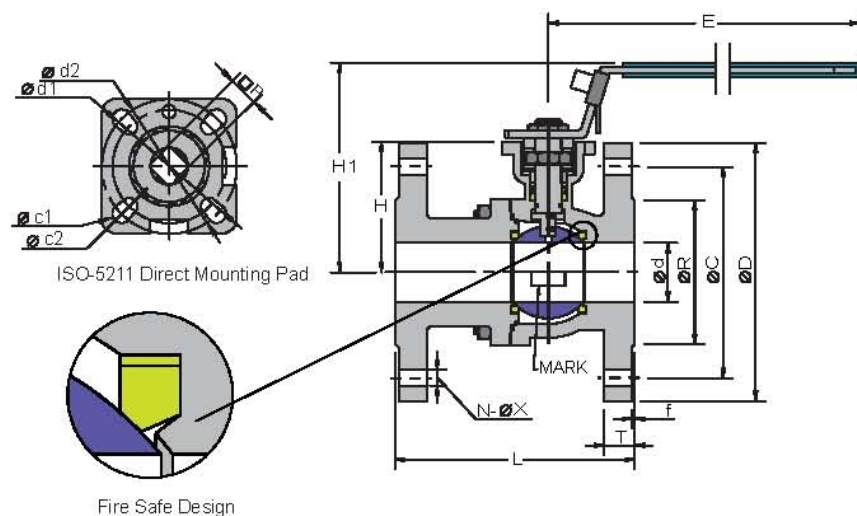
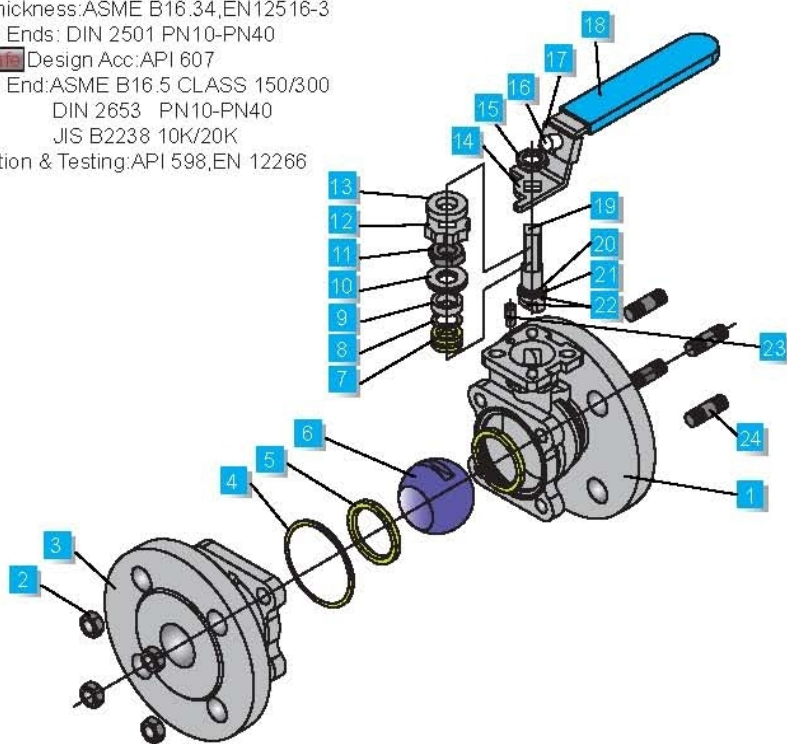

Unit:mm

DN	PN	L	L1	ød	øR	øC	øD	H	H1	E	T	f	N	øX	ød1	ød2	øc1	øc2	□P	ISO-5211	
DN15	1/2"	PN10/40	115	130	15	45	65	95	48	93	110	16	4	14	42	36	6	6	9	F03-F04	
DN20	3/4"		120	150	20	58	75	105	53	93	130	18	2	4	14	42	36	6	6	9	F03-F04
DN25	1"		125	160	25	68	85	115	58	99	130	18	2	4	14	50	42	7	6	11	F04-F05
DN32	1-1/4"		130	180	32	78	100	140	71	120	145	18	2	4	18	50	42	7	6	11	F04-F05
DN40	1-1/2"		140	200	38	88	110	150	75	125	145	18	3	4	18	70	50	9	7	14	F05-F07
DN50	2"	150	230	50	102	125	165	85	130	160	20	3	4	18	70	50	9	7	14	F05-F07	
DN65	2-1/2"	PN10/25	170	290	65	122	145	185	102	145	185	18	4	18	102	70	11	9	17	F7-F10	
		PN25/40							107			22									8
DN80	3"	PN10/25	180	310	78	138	160	200	112	155	220	20	3	18	102	70	11	9	17	F7-F10	
		PN25/40							117			24									
DN100	4"	PN10/25	190	350	100	158	180	220	142	NA	NA	20	3	8	18	102	70	11	9	22	F07-F10
		PN25/40				162						190									
DN125	5"	PN10/25	325	400	125	188	210	250	185	NA	NA	22	3	8	18	NA	125	NA	14	27	F12
		PN25/40				220						270									
DN150	6"	PN10/25	350	450	150	212	240	285	204	NA	NA	22	3	8	22	NA	125	NA	14	27	F12
		PN25/40				218						250									

Face to Face: L=F4/F5, L1=F1/F7